

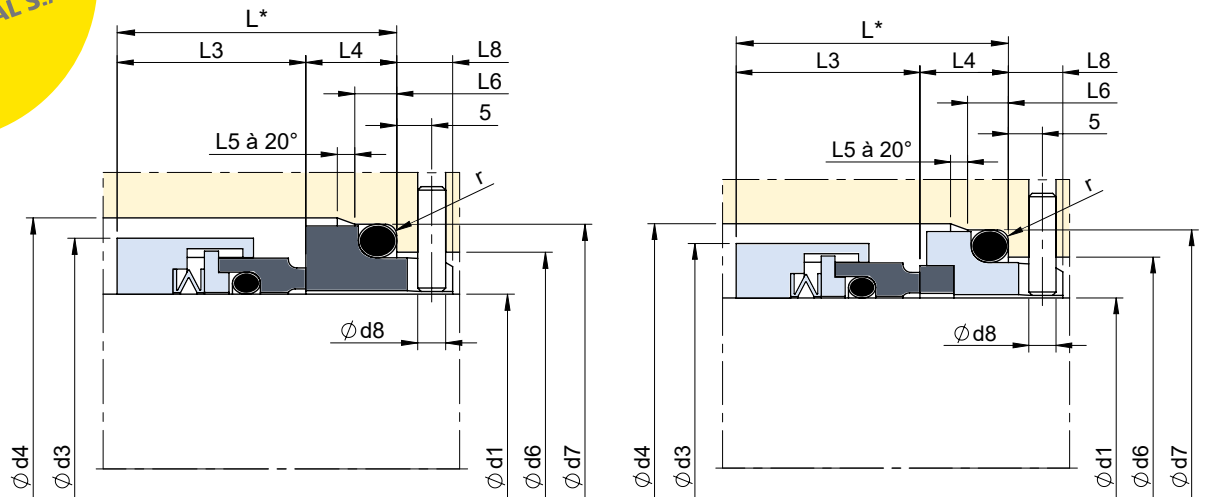

# LATTYseal U 68



**d8** : Ø3 mm : ≤ Ø35  
 Ø4 mm : ≥ Ø38  
 Emmanchement serré  
 (Tight to sleeve)

**r** : 1.6 mm : ≤ Ø55  
 2.5 mm : ≥ Ø58

**CONDITIONS DE FONCTIONNEMENT (Paramètres non associés)**  
 OPERATING CONDITIONS (Not associated parameters)

**T°** : de -20°C à 220°C

**P** : < 1 Mpa (10 bar)

**V** : < 15 m/s

## VERSION MÉTRIQUE

d1 h6 nominal	d3	d4 mini	d6 H11	d7 H8	L*	L3	L4	L5 ±0.1	L6 ±0.1	L8
16	26	28	23	27	28	20	8	2	5	7.5
18	32	34	27	33	30.5	21.5	9	2	5	7.5
20	34	36	29	35	30.5	21.5	9	2	5	7.5
22	36	38	31	37	30.5	21.5	9	2	5	7.5
24	38	40	33	39	32.5	23	9.5	2	5	7.5
25	39	41	34	40	33.5	24	9.5	2	5	7.5
28	42	44	37	43	33.5	23	10.5	2	5	7
30	44	46	39	45	34.5	24	10.5	2	5	7.5
32	46	48	42	48	34.5	24	10.5	2	5	7.5
33	47	49	42	48	34.5	24	10.5	2	5	7.5
35	49	51	44	50	34.5	24	10.5	2	5	7.5
38	54	58	49	56	38	26.5	11.5	2	6	8.5
40	56	60	51	58	39	27.5	11.5	2	6	8.5
43	59	63	54	61	39	27.5	11.5	2	6	8.5
45	61	65	56	63	39	27.5	11.5	2	6	8.5
48	64	68	59	66	39	27.5	11.5	2	6	8.5
50	66	70	62	70	40	27	13	2.5	6	8
53	69	73	65	73	40	27	13	2.5	6	8
55	71	75	67	75	40	27	13	2.5	6	8
58	78	83	70	78	42	28.5	13.5	2.5	6	8
60	80	85	72	80	42	28.5	13.5	2.5	6	8
63	83	88	75	83	45	31.5	13.5	2.5	6	8
65	85	90	77	85	45	31.5	13.5	2.5	6	8
68	88	93	81	90	47	33.5	13.5	2.5	7	8
70	90	95	83	92	47	32	15	2.5	7	8
75	99	104	88	97	47	32	15	2.5	7	8.2
80	104	109	95	105	48	33	15	3	7	8
85	109	114	100	110	48	32	16	3	7	8
90	114	119	105	115	54	38	16	3	8	8
95	119	124	110	120	54	38	16	3	8	8
100	124	129	115	125	54	38	16	3	8	8

Correspondant à la norme NFE 29991 et DIN 24960 sauf L\* qui est inférieur à L1K norme  
 Complies with NFE 29991 and DIN 24960 except for L\* which is less than the L1K in the standards

LATTY International – 21226 (01/2022)



### Site de production

1, rue Xavier Latty – 28160 BROU – FRANCE / Tél. +33 (0)2 37 44 77 77 / customerservice@latty.com

Les indications portées sur cette documentation ne le sont qu'à titre indicatif et ne sauraient engager la responsabilité de LATTY International S.A.  
 The information given in this document is for guidance only and does not commit LATTY International S.A. in any way