

Single-seal

LATTYSEAL B 17210 B

Dynamic sealing through complete, balanced mechanical seal

BELLOWS MECHANICAL SEAL FOR HIGH-TEMPERATURE APPLICATIONS

- SELF-CLEANING MECHANICAL SEAL
- BELLOWS MECHANICAL SEAL

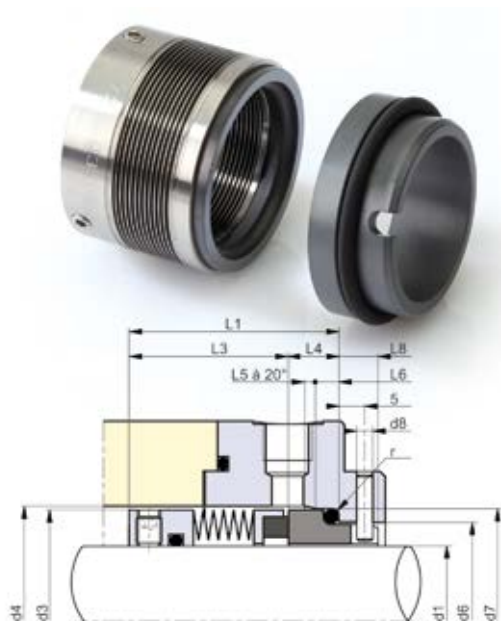

OPERATING PARAMETERS (NOT ASSOCIATED)

Pressure : 0 to 20 bar
Temperature : -20 °C to 200°C
Speed : 20 m/s

COMPOSITION

Supplied with FKM O-ring Pure silicon carbide (U6)

TYPES OF INDUSTRIES



FLUIDS

All corrosive, abrasive and slightly clogging fluids.

GUIDELINES, STANDARDS AND APPROVALS (ON REQUEST)



d1 nominal h6	d3	d4 mini	d6 H 11	d7 H8	L1	L3	L4	L5 ± 0,1	L6 ± 0,1	L8
25	37	41	34	40	40	30.5	9.5	2	5	7.5
28	42.8	44	37	43	42.5	32	10.5	2	5	7
30	43	46	39	45	42.5	32	10.5	2	5	7.5
32	43	48	42	48	42.5	32	10.5	2	5	7.5
33	46	49	42	48	42.5	32	10.5	2	5	7.5
35	49.2	51	44	50	42.5	32	10.5	2	5	7.5
38	49.4	58	49	56	45	33.5	11.5	2	6	8.5
40	55.5	60	51	58	45	33.5	11.5	2	6	8.5
43	58.7	63	54	61	45	33.5	11.5	2	6	8.5
45	58.7	65	56	63	45	33.5	11.5	2	6	8.5
48	61.9	68	59	66	45	33.5	11.5	2	6	8.5
50	65.1	70	62	70	47.5	34.5	13	2.5	6	8
53	68.2	73	65	73	47.5	34.5	13	2.5	6	8
55	71.4	75	67	75	47.5	34.5	13	2.5	6	8
58	74.6	83	70	78	52.5	39	13.5	2.5	6	8
60	74.6	85	72	80	52.5	39	13.5	2.5	6	8
63	80.9	88	75	83	52.5	39	13.5	2.5	6	8
65	84.1	90	77	85	52.5	39	13.5	2.5	6	8
68	87.3	93	81	90	52.5	39	13.5	2.5	7	8
70	87.3	95	83	92	60	45	15	2.5	7	8
75	95.2	104	88	97	60	45	15	2.5	7	8
80	98.4	109	95	105	60	45	15	3	7	8
85	104.8	114	100	110	60	44	16	3	7	8
90	108	119	105	115	65	49	16	3	7	8
95	114.3	124	110	120	65	49	16	3	7	8
100	120.7	129	115	125	65	49	16	3	7	8

Complies with NF E 29991 and DIN 24960 d8 (tight to sleeve) : 3 mm for d1 25 to 35 - 4 mm for d1 38 to 100 r : 1,5 mm for d1 25 to 55 - 2,5 mm for d1 58 to 100.

The maximum temperature, pressure and speed given in this document cannot be associated in any case.

