

Cartridge version

CARTSEAL B 24610

Dynamic sealing through single cartridge seal

CONNECTION WITH FLUSHING AS STANDARD VERSION

- ACS, ATEX (IIGD IIA-IIB T6 À T3), EC 1935/2004 AND FDA AS STANDARD
- COMPLETE, BALANCED STATIONARY MECHANICAL SEAL FOR HIGH-ROTATION SPEEDS, ALLOWS FOR ANGULAR SHAFT MISALIGNMENT
- SPRINGS ENCAPSULATED IN THE CARTRIDGE BOX, NO LOSS OR IMPROPER HANDLING DURING INSTALLATION
- SELF-TURNING SETTING CLAMPS

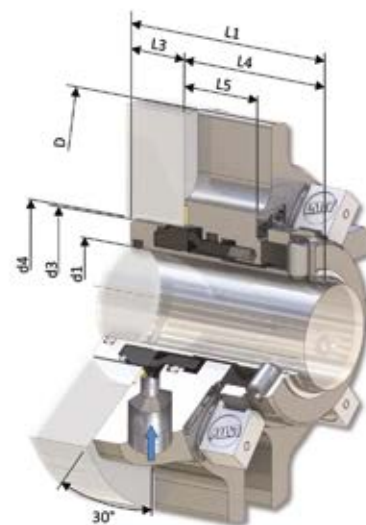
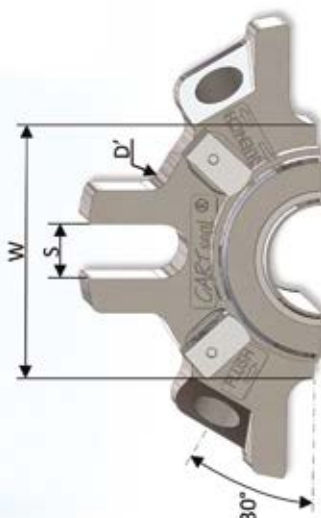

OPERATING PARAMETERS (NOT ASSOCIATED)

Pressure : 0 to 25 bar
Temperature : -20 °C to 200 °C
Speed : 20 m/s

COMPOSITION

Friction faces: Silicon carbide / silicon carbide (U6/U6) or silicon carbide / resin-impregnated carbon (U6/B1). High-performance surface drive system: prevents breakage when starting with clogging products and ensures even effort distribution. FLUSHING : % Gaz - L6 : Flushing ports position

TYPES OF INDUSTRIES



FLUIDS

All corrosive, abrasive and slightly clogging fluids.

GUIDELINES, STANDARDS AND APPROVALS (ON REQUEST)



Cartridge version

CARTSEAL B 24610

Dynamic sealing through single cartridge seal

METRIC VERSION

d1 nominal h6	d3	d4 mini	d4 maxi	L1	L3	L4	L5	D	D'	S	W
25	40	41	51	61	17	44	23	105	75	12.5	58
28	43	44	52	61	17	44	23	105	83	12.5	59
30	45	46	56	61	17	44	23	105	83	12.5	63
32	47	48	57	61	17	44	23	110	85	12.5	64
33	48	49	57	61	17	44	23	110	86	12.5	64
35	50	51	61	61	17	44	23	115	85	12.5	68
38	55	58	66	61	17	44	23	125	90	12.5	73
40	57	60	68	61	17	44	23	125	92	14.7	75
43	60	63	70	61	17	44	23	133	95	14.7	77
45	62	65	73	61	17	44	23	141	97	14.7	80
48	65	68	75	61	17	44	23	141	100	14.7	82
50	67	70	78	61	17	44	23	150	102	14.7	85
53	70	73	81	61	17	44	23	150	105	14.7	88
55	72	75	83	61	17	44	23	150	107	18	90
60	80	85	91	61	17	44	23	157	123	18	98
65	85	90	98	61	17	44	23	165	128	18	105
70	90	95	108	61	17	44	23	180	132	18	115

IMPERIAL VERSION

d1 nominal	d1 nominal inches	d3	d4 mini	d4 maxi	L1	L3	L4	L5	D	D'	S	W
1	1"	40	41	51	61	17	44	23	105	75	12.5	58
1.125	1 ¹ / ₈	45	46	56	61	17	44	23	105	83	12.5	63
1.25	1 ¹ / ₄	47	48	57	61	17	44	23	110	85	12.5	64
1.375	1 ³ / ₈	50	51	61	61	17	44	23	115	85	12.5	68
1.5	1 ¹ / ₂	55	58	66	61	17	44	23	125	90	12.6	73
1.625	1 ⁵ / ₈	60	63	70	61	17	44	23	133	95	14.7	77
1.75	1 ³ / ₄	62	65	73	61	17	44	23	141	97	14.7	80
1.875	1 ⁷ / ₈	65	68	75	61	17	44	23	141	100	14.7	82
2	2"	70	73	81	61	17	44	23	150	105	14.7	88
2.125	2 ¹ / ₈	72	75	83	61	17	44	23	150	107	18	90
2.25	2 ¹ / ₄	78	83	90	61	17	44	23	157	114	18	97
2.375	2 ³ / ₈	80	85	91	61	17	44	23	157	123	18	98
2.5	2 ¹ / ₂	85	90	98	61	17	44	23	165	128	18	105
2.625	2 ⁵ / ₈	88	93	100	61	17	44	23	165	131	18	107
2.75	2 ³ / ₄	90	95	108	61	17	44	23	180	132	18	115